

MET-L-FLEX® MESH CUSHIONS

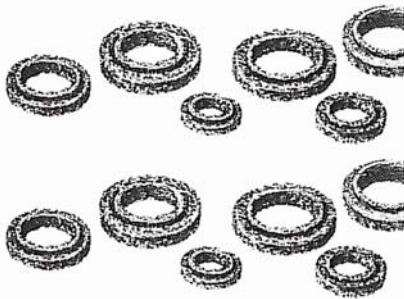

ANNULAR AND RING CUSHIONS WITH SHEAR BUSHING MOUNTING

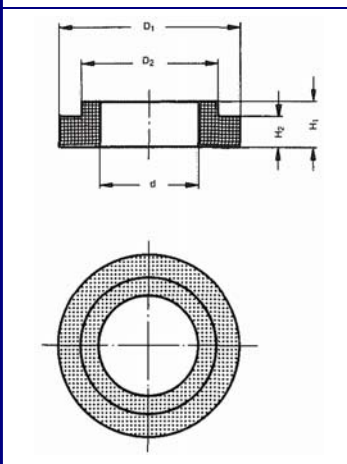

Ring style cushions with an integral bushing are installed into a reciprocal counter-bore in the supporting or payload structure. They can be used independently or in series for multi axis isolation and damping. Suspension of isolated pipes or tubing as well as compression seats of equipment are possible. When assembled in series with a shoulder bolt or pre-load tube and fastener through the center, a fully isolated and rebound protected equipment support system is possible.

Natural frequency = 30-50 Hz.

INSTALLATION EXAMPLES

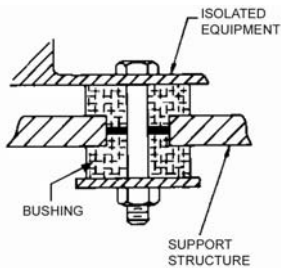

EQUIPMENT SUSPENSION

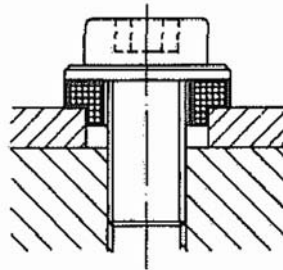

ALIGNMENT BUSHING

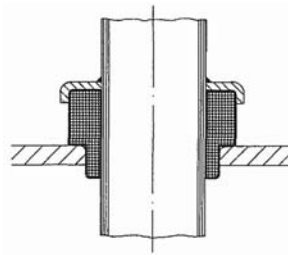

ISOLATED TUBING BUSHING

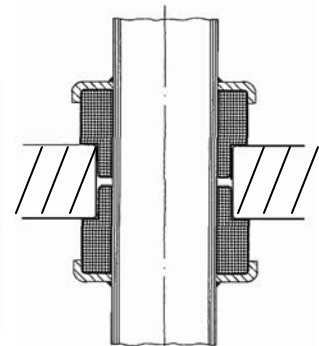

ISOLATED BULKHEAD BUSHING

PART NO.	D1	D2	d	H1	H2	MAX LOAD	DEFLECTION
000 51 475	(.669in)	(0.500in)	(.323in)	(.217in)	(.138in)	(7.86lb)	(~.008in)
000 51 476	(.839in)	(.610in)	(.425in)	(.217in)	(.138in)	(22.5lb)	(~.024in)
000 51 477	(.965in)	(.701in)	(.531in)	(.256in)	(1.77in)	(33.7lb)	(~.028in)
000 51 478	(1.165in)	(.894in)	(.701in)	(.295in)	(.197in)	(45lb)	(~.063in)
000 51 479	(1.441in)	(.109in)	(.850in)	(.295in)	(.197in)	(45lb)	(~.067in)
000 51 475	17mm	12.7mm	8.2mm	5.5mm	3.5mm	0.035kN	~0.2mm
000 51 476	21.3mm	15.5mm	10.8mm	5.5mm	3.5mm	0.1kN	~0.6mm
000 51 477	24.5mm	17.8mm	13.5mm	6.5mm	4.5mm	0.15kN	~0.7mm
000 51 478	29.6mm	22.7mm	17.8mm	7.5mm	5mm	0.2kN	~1.6mm
000 51 479	36.6mm	27.8mm	21.6mm	7.5mm	5mm	0.2kN	~1.7mm

MET-L-FLEX® MESH CUSHIONS

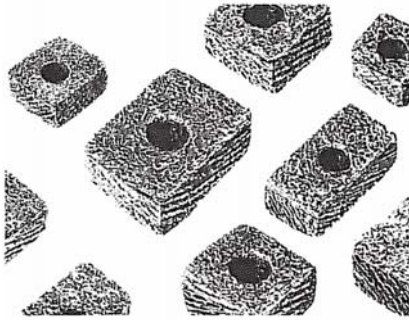

SQUARE AND RECTANGULAR CUSHIONS WITH COUNTER-BORE MOUNTING HOLE

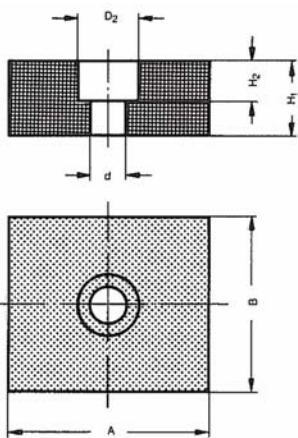

Square or rectangular metal cushions with integral mounting holes can be attached directly to the payload, supporting structure or a separate retention clamp. This allows for optimum positioning of the cushion in relation to the supporting structure or payload with minimal number of cushions. Suspension of isolated pipes or tubing as well as compression seats of equipment are possible when installed with a standard socket head cap screw fastener.

Natural frequency = 15-30 Hz.

INSTALLATION EXAMPLE

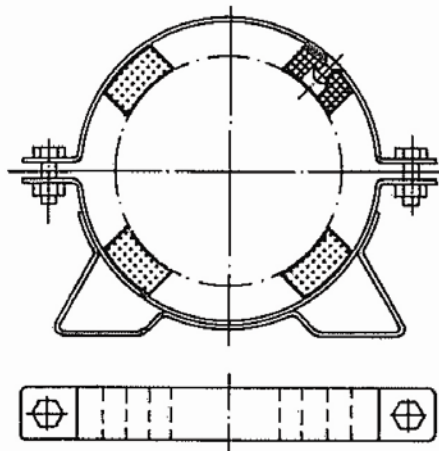

SADDLE STYLE PIPE CLAMP

PART NO.	A	B	d	D2	H1	H2	MAX LOAD	DEFLECTION
000 51 327	(1.150in)	(1.150in)	(.252in)	(.433in)	(.748in)	(.335in)	(168lb)	(~.217in)
000 51 313	(2.560in)	(1.969in)	(.354in)	(.787in)	(.984in)	(.354in)	(1,124lb)	(~.205in)
000 51 327	29.2mm	29.2mm	6.4mm	11mm	19mm	8.5mm	0.75kN	~5.5mm
000 51 313	65mm	50mm	9mm	20mm	25mm	9mm	5.0kN	~5.2mm

MET-L-FLEX® MESH CUSHIONS

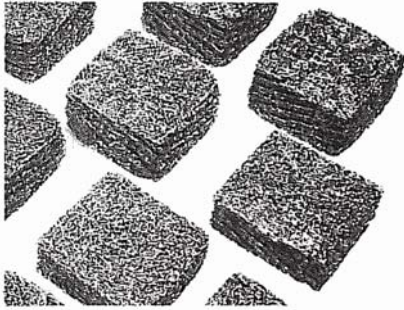

SQUARE AND RECTANGULAR CUSHIONS

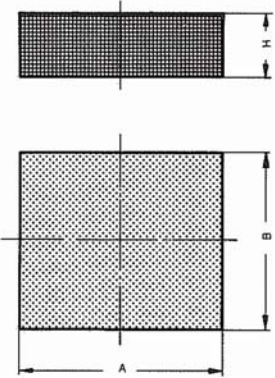

SEE TABLE

Square metal cushions, when assembled with channel-band saddle or hoop clamps for use in pipe and tubing suspensions, provide a full circumferential geometry isolator with the capability for thermal expansion and contraction. A flexible sliding fit for the entire run of pipe or tube is also a result of this design approach.

Natural frequency = 15-30 Hz.

INSTALLATION EXAMPLES

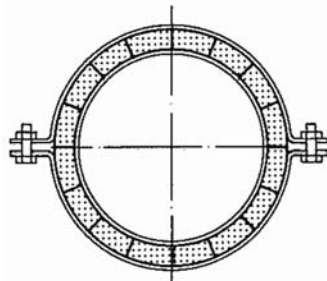
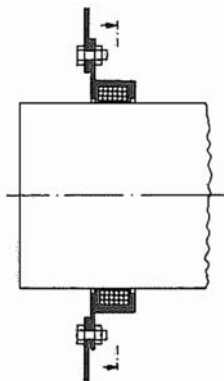

FULL CIRCUMFERENCE
PIPE OR TUBING SUSPENSION

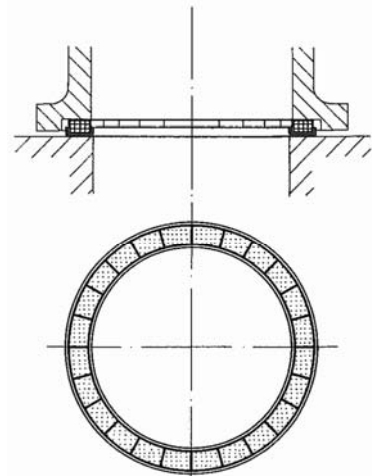

FLEXIBLE JOINT
INTEGRAL TO HOUSING

PART NO.	A	B	H	MAX LOAD	DEFLECTION
000 50 235	(1.083in)	(1.083in)	(.610in)	(1,124lb)	(-.098in)
000 51 229	(1.142in)	(1.142in)	(.610in)	(337lb)	(-.177in)
000 50 237	(1.811in)	(1.476in)	(.846in)	(2,810lb)	(-.130in)
000 51 323	(2.363in)	(1.220in)	(.433in)	(563lb)	(-.157in)
000 50 235	27.5mm	27.5mm	15.5mm	5.0 kN	~2.5mm
000 51 229	29mm	29mm	15.5mm	1.5 kN	~4.5mm
000 50 237	46mm	37.5mm	21.5mm	12.5kN	~3.3mm
000 51 323	60.5mm	31mm	11mm	2.5kN	~4mm

MET-L-FLEX® MESH CUSHIONS



ANNULAR AND RING CUSHIONS WITH COUNTER-BORE MOUNTING HOLE

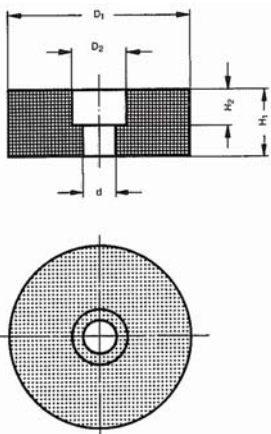

Rings style metal cushions with integral mounting holes can be attached directly to the payload or supporting structure when used as a foot pad or bumper stop. This allows for optimum positioning of the cushion in relation to the supporting structure or payload with minimal number of cushions. Easy installation is achieved with a standard socket head cap screw fastener.

Natural frequency = 15-20 Hz.

INSTALLATION EXAMPLES

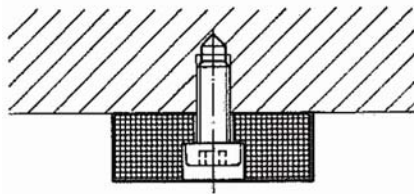

MOUNTING PAD

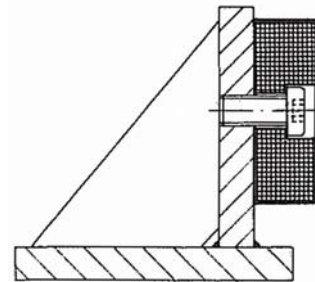

BUMPER STOP

PART NO.	D1	D2	d	H1	H2	MAX LOAD	DEFLECTION
000 51 485	(.787in)	(.374in)	(.213in)	(.492in)	(.217in)	(50.6lb)	(~.110in)
000 51 486	(.795in)	(.433in)	(.248in)	(.512in)	(.236in)	(67.4lb)	(~.118in)
000 51 487	(.984in)	(.472in)	(.272in)	(.610in)	(.335in)	(90lb)	(~.138in)
000 51 488	(1.400in)	(.630in)	(.390in)	(.787in)	(.433in)	(112lb)	(~.236in)
000 51 489	(2.067in)	(.709in)	(.441in)	(.906in)	(.394in)	(786.8lb)	(~276in)
000 51 485	20mm	9.5mm	5.4mm	12.5mm	5.5mm	0.225kN	~2.8mm
000 51 486	20.2mm	11mm	6.3mm	13mm	6mm	0.3kN	~3mm
000 51 487	25mm	12mm	6.9mm	15.5mm	8.5mm	0.4kN	~3.5mm
000 51 488	35.5mm	16mm	9.9mm	20mm	11mm	0.5kN	~6mm
000 51 489	52.5mm	18mm	11.2mm	23mm	10mm	3.5kN	~7mm

MET-L-FLEX® MESH CUSHIONS



ANNULAR AND RING CUSHIONS WITH MOUNTING HOLE

Rings style metal cushions are installed in series to isolated equipment from the supporting structure. They can be stacked along a common center to obtain additional isolation or deflection capability. Easy installation is achieved with a standard threaded fastener, washer, nut and pre-load tube.

Natural frequency = 15-20 Hz.

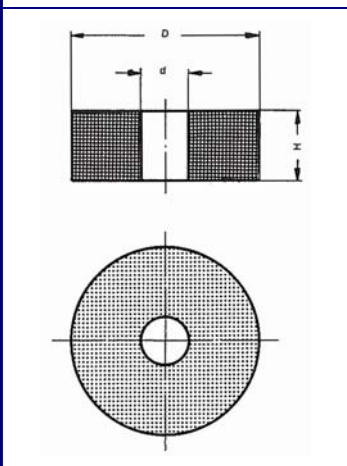

INSTALLATION EXAMPLE

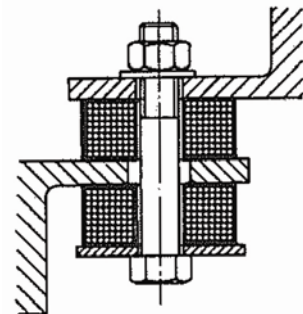

EQUIPMENT SUPPORT

PART NO.	D	d	H1	MAX LOAD	DEFLECTION
000 51 460	(.583in)	(.343in)	(.394in)	(9lb)	(-.083in)
000 51 461	(.780in)	(.303in)	(.394in)	(78.7lb)	(-.126in)
000 51 462	(.866in)	(.248in)	(.610in)	(112lb)	(-.217in)
000 51 463	(.929in)	(.457in)	(.610in)	(135.9lb)	(-.207in)
000 51 464	(1.122in)	(.382in)	(.590in)	(179.8lb)	(-.207in)
000 51 465	(1.358in)	(.382in)	(.590in)	(224.8lb)	(-.217in)
000 51 466	(1.575in)	(.464in)	(.787in)	(337.2lb)	(-.272in)
000 51 467	(1.673in)	(.835in)	(.787in)	(337.2lb)	(-.228in)
000 51 468	(2.110in)	(.780in)	(.787in)	(505.8lb)	(-.276in)
000 51 469	(2.465in)	(1.543in)	(.787in)	(674.4lb)	(-.228in)
000 51 460	14.8mm	8.7mm	10mm	0.04kN	~2.1mm
000 51 461	19.8mm	7.7mm	10mm	0.35kN	~3.2mm
000 51 462	22mm	6.3mm	15.5mm	0.5kN	~5.5mm
000 51 463	23.6mm	11.6mm	15.5mm	0.6kN	~5.3mm
000 51 464	28.5mm	9.7mm	15mm	0.8kN	~5.3mm
000 51 465	34.5mm	9.7mm	15mm	1.0kN	~5.5mm
000 51 466	40mm	11.8mm	20mm	1.5kN	~6.9mm
000 51 467	42.5mm	21.2mm	20mm	1.5kN	~5.8mm
000 51 468	53.6mm	19.8mm	20mm	2.25kN	~7mm
000 51 469	62.6mm	39.2mm	20mm	3.0kN	~5.8mm