

# TTB MOUNT SERIES

## Features

- Available in Silicone or Neoprene
- Axial to radial stiffness of 2.3:1
- Mid frequency isolation
- Aluminum construction

## Benefits

- Attenuates a 15g, 11 millisecond half-sine shock to 10g's
- Attenuates a 30g, 11 millisecond half-sine crash safety shock to 16 g's
- Lightweight

## Load Range

- 3 load ratings to 30 lbs. per mount

Mid-frequency, low profile, high deflection mounts for protection from severe vibration and shock.



Barry TT-B Mounts are mid-frequency isolators with a large deflection capacity, designed to give both shock and vibration isolation protection. The standard Neoprene version is for applications where temperature extremes are not a factor.

## Applications

- Shipping containers
- Airborne electronics & racking
- Shipboard equipment
- Mobile mounted equipment
- Other applications where high amplitude, low frequency vibration is present

|                               |   |
|-------------------------------|---|
| NATURAL FREQUENCY             | 25-35 Hertz   |
| TRANSMISSIBILITY AT RESONANCE | 4.0 Max. (Hi-Damp Silicone)<br>10.0 Max. (Neoprene) |
| RESILIENT ELEMENT             | Hi-Damp Silicone or Neoprene                        |
| STANDARD MATERIALS            | Aluminum<br>(Grounding Strap Beryllium Copper)      |
| WEIGHT                        | 6.5 oz.   |

## Environmental Data

- Hi-Damp Silicone operating temperature range is -67°F to +300°F (-55°C to +150°C) and is resistant to fungus and ozone.
- Neoprene operating temperature range is -20°F to +180°F (-30°C to +82°C) and is resistant to oil and ozone.

# TTB Mount Series

## Dimensions & Performance Characteristics

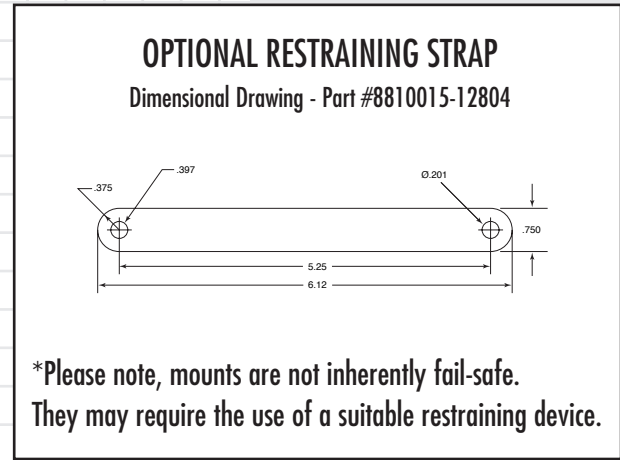
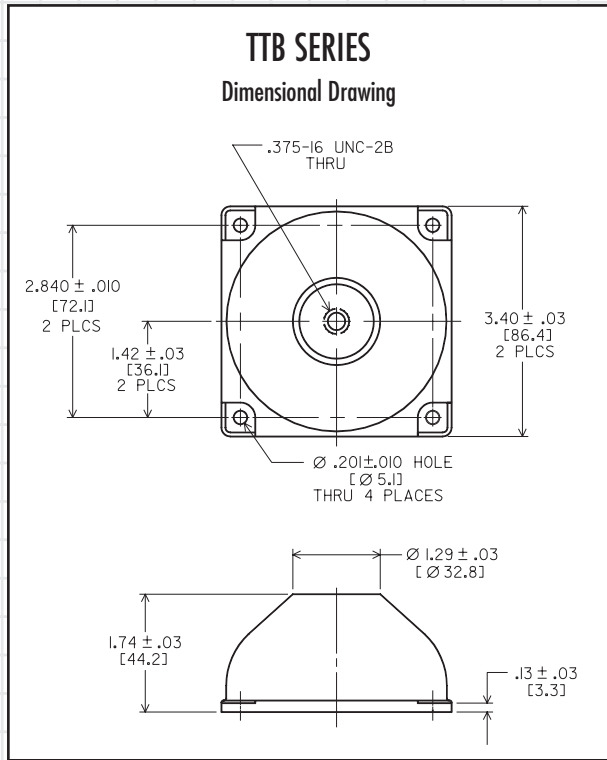

| ORDERING INFORMATION |          |                   |          |
|----------------------|----------|-------------------|----------|
| PART #               |          | LOAD RANGE (lbs.) |          |
| Neoprene             | Silicone | Neoprene          | Silicone |
| TTN-B-1              | TT-B-1   | 12                | 10       |
| TTN-B-2              | TT-B-2   | 20                | 18       |
| TTN-B-3              | TT-B-3   | 30                | 25       |

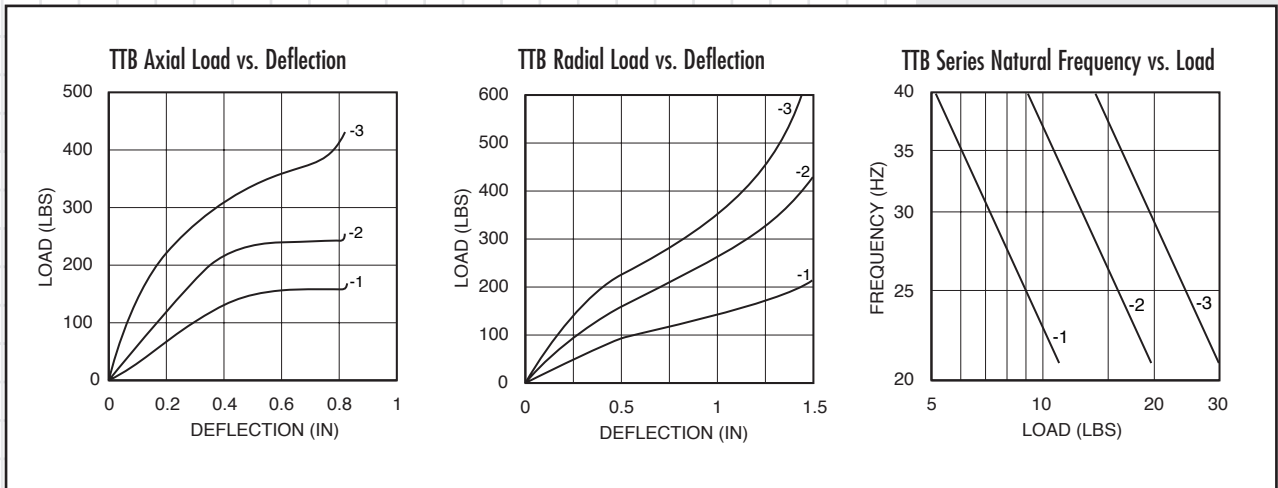

For more information contact:



5058 Cedar Ridges Lane RR#1  
 Inverary, ON K0H-1X0  
 P: 613-544-2002  
 F: 613-544-2003  
 www.bdproduct.ca