

ELASTOMER SPRING SERIES

Features

- All elastomer isolators
- Very slight pressure set
- Minimal wear through abrasion
- Excellent resistance to oil and ozone
- Stackable

Benefits

- Quieter and safer operation than steel
- Eliminates die damage caused by shattered springs
- Longer stroke at same load

Load Range

- Load range up to 15,000 lbs.

Low cost, compact, all elastomer mounts for vibration and noise control.



When compared to other types of springs, Barry Elastomer Springs have proven to be the safest, most efficient and reliable compression material for punching, stamping and drawing dies. Elastomer Springs can be used in other applications requiring exceptionally high energy storage in a small area.

Applications

- Punching Dies
- Stamping Dies
- Drawing Dies

Since Barry Controls introduced elastomer springs, a steadily increasing number of metal fabricators in the aircraft, automobile, appliance and electronics industries are making use of their specific advantages which are: higher loads, increased durability, better performance, freedom from maintenance and a very long life.

Environmental Data

- Neoprene elastomer has an operating temperature range of -20°F to +180°F (-30°C to +85°C) and is resistant to oils, most solvents, salt spray and ozone.

Elastomer Spring Series

Dimensions & Load Range Data

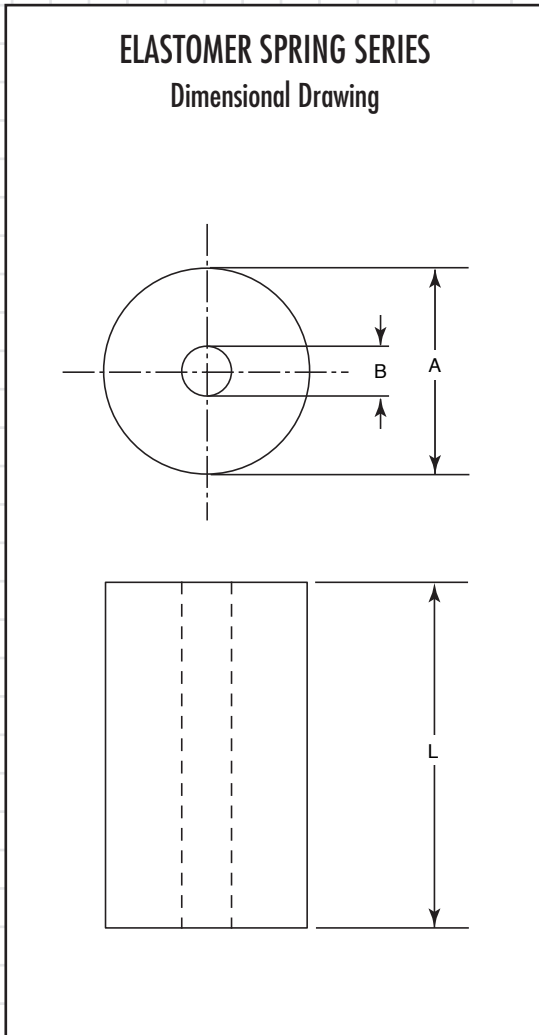

Dimensions and data are subject to change without notice.

For technical, design, or application assistance, call toll free:

1-800-BARRY MA

Part Number	A	B	L	R	D	T
ES-3500	.63"	.25"	15/32"	436	.17"	72
ES-3501			5/8"	353	.22"	77
ES-3502			25/32"	292	.27"	80
ES-3503			1"	236	.34"	83
ES-3510	.787"	.33"	5/8"	610	.22"	133
ES-3511			25/32"	482	.28"	132
ES-3512			1"	381	.35"	133
ES-3512			1.25"	287	.44"	126
ES-3520	1.00"	.41"	25/32"	787	.28"	215
ES-3521			1"	598	.35"	209
ES-3522			1.25"	524	.44"	229
ES-3523			1.562"	440	.55"	241
ES-3530	1.25"	.53"	1.25"	1031	.44"	451
ES-3531			1.578"	828	.55"	471
ES-3532			1.969"	651	.69"	456
ES-3533			2.50"	517	.87"	452
ES-3540	1.56"	.53"	1.25"	1790	.44"	783
ES-3541			1.578"	1434	.55"	816
ES-3542			1.969"	1148	.69"	804
ES-3543			2.50"	931	.87"	815
ES-3544			3.156"	744	1.10"	830
ES-3550	2.00"	.66"	1.25"	2959	.44"	1295
ES-3551			1.578"	2411	.55"	1371
ES-3552			1.969"	1852	.69"	1296
ES-3553			2.50"	1482	.87"	1297
ES-3554			3.156"	1192	1.10"	1330
ES-3555			3.937"	950	1.38"	1330
ES-3560	2.50"	.66"	1.25"	4565	.44"	1997
ES-3561			1.578"	3650	.55"	2076
ES-3562			1.969"	2830	.69"	1981
ES-3563			2.50"	2286	.87"	2000
ES-3564			3.156"	1809	1.10"	2018
ES-3565			3.937"	1468	1.38"	2055
ES-3566			4.922"	1375	1.72"	2406
ES-3570	3.15"	.83"	1.25"	9088	.44"	3926
ES-3571			1.578"	7038	.55"	4003
ES-3572			1.969"	5768	.69"	4038
ES-3573			2.50"	4572	.87"	4000
ES-3574			3.156"	3485	1.10"	3889
ES-3575			3.937"	2567	1.38"	3594
ES-3576			4.922"	2010	1.72"	3518
ES-3580	3.94"	.83"	1.25"	15216	.44"	6657
ES-3581			1.578"	10427	.55"	5930
ES-3582			1.969"	8466	.69"	5926
ES-3583			2.50"	6435	.87"	5631
ES-3584			3.156"	4648	1.10"	5186
ES-3585			3.937"	3440	1.38"	4816
ES-3586			4.922"	2540	1.72"	4445
ES-3590	4.92"	1.06"	1.25"	33815	.44"	14794
ES-3591			1.578"	22810	.55"	12973
ES-3592			1.969"	14817	.69"	10372
ES-3593			2.50"	10584	.87"	9261
ES-3594			3.156"	7138	1.10"	7965
ES-3595			3.937"	5680	1.38"	7952
ES-3596			4.922"	4022	1.72"	7039
ES-3597			6.312"	3102	2.21"	6853

R = Spring Rate, lbs./inch deflection +/- 20%

D = Maximum recommended deflection -35%L

T = Approximate total load at maximum deflection +/- 20%

For more information contact:

BLACK DIAMOND
Products

5058 Cedar Ridges Lane RR#1
Inverary, ON K0H-1X0

P: 613-544-2002

F: 613-544-2003

www.bdproduct.ca