

# BARRY-FLEX ISOLATOR SERIES (GBC01 /GBC02)

## Features

- Aluminum alloy construction
- Meets requirements of MIL-STD-810 and DEF.STAN.07-55
- Low-profile design
- Unique cooling feature

## Benefits

- Static deflection of .04" under maximum load
- Special elastomer formulation meets damping and high deflection characteristics of current defense standards
- Up to .47" dynamic deflection available, despite low profile
- Elastomer will not overheat during prolonged dynamic excursions

## Load Range

- GBC01 Series available in 3 load ratings from 8.8 to 17.6 lbs.
- GBC02 Series available in 4 load ratings from 17.6 to 40 lbs.

Low-profile, high-deflection elastomeric shock & vibration isolators protect sensitive military equipment in harsh environments.



Barry-Flex isolators are designed for harsh environments where high-amplitude shock and vibration are encountered. Their rugged design and high deflection capabilities are ideal for this type of environment.

## Applications

- Electronic packages, computers & communications equipment installed within military vehicles

NATURAL FREQUENCY	15 Hertz at maximum load
TRANSMISSIBILITY AT RESONANCE	4.0
RESILIENT ELEMENT	Barry LT
STANDARD MATERIALS	Aluminum alloy
WEIGHT	GBC01 = 1.45 oz. GBC02 = 2.68 oz.

## Environmental Data

- Operating temperature range of -40°F to 180°F (-40°C to +82°C).
- Can be stored at temperatures as low as -67°F (-55°C).
- Unique cooling feature ensures that elastomer does not overheat during prolonged dynamic excursions.

# Barry-Flex Isolator Series

## Dimensions & Performance Characteristics

**GBC01 SERIES (dimensions in mm)**

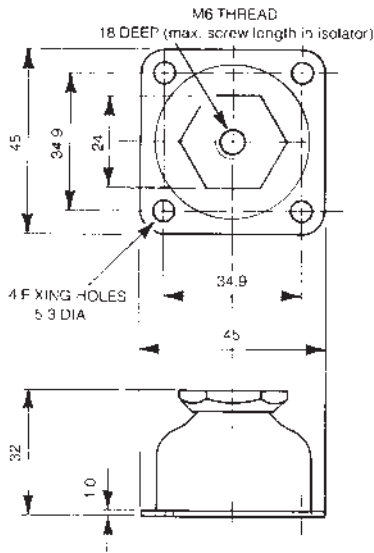

**Load vs. Deflection**

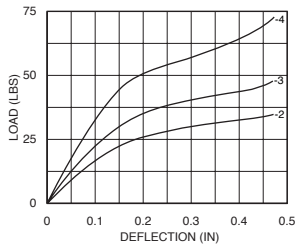

**Load vs. Natural Frequency**

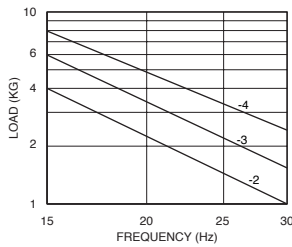

**Part Numbers Load**

Part Numbers	Load
GBC01-2-TM6-L	4
GBC01-3-TM6-L	6
GBC01-4-TM6-L	8

**GBC02 SERIES (dimensions in mm)**

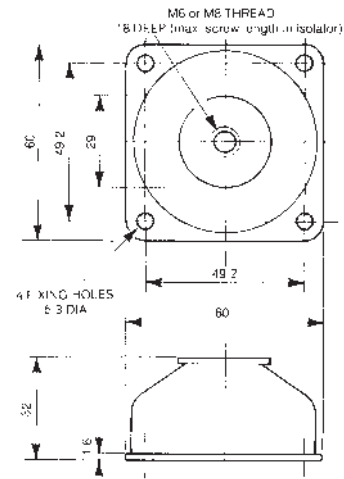

**Load vs. Deflection**

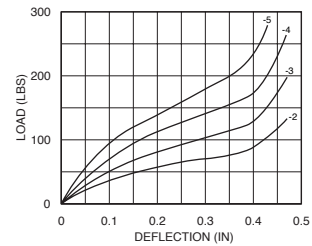

**Load vs. Natural Frequency**

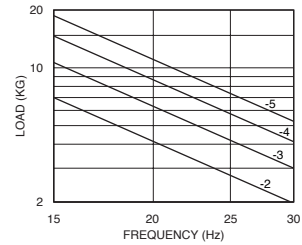

**Part Numbers Load**

Part Numbers	Load
GBC02-2-TM6-L or GBC02-2-TM8-L	7
GBC02-3-TM6-L or GBC02-3-TM8-L	10
GBC02-4-TM6-L or GBC02-4-TM8-L	15
GBC02-5-TM6-L or GBC02-5-TM8-L	20

For more information contact:

**BLACK DIAMOND**  
Products

5058 Cedar Ridges Lane RR#1

Inverary, ON K0H-1X0

P: 613-544-2002

F: 613-544-2003

www.bdproduct.ca